

PART NUMBER	SIZE	"R"	"O"	"H"	"S" MIN	"B" MIN	"L"
5234097	3/4"	4 1/2"	3/8"	1 3/4"	1 1/2"	3/4"	1 3/4"
5236402	1"	5 3/4"	5/16"	2 3/16"	1 7/8"	7/8"	2 1/4"
5236403	1 1/4"	7 1/4"	9/16"	2 3/4"	2"	1"	2 7/8"
5234094	1 1/2"	8 1/4"	5/8"	3 1/8"	2"	1 1/8"	3 1/4"
5234067	2"	9 1/2"	3/4"	3 5/8"	2"	1 1/8"	3 3/4"
5234096	2 1/2"	10 1/2"	13/16"	4"	3"	1 1/2"	4 1/8"
5234068	3"	13"	1"	5"	3 1/8"	1 5/8"	5 1/8"
5234095	3 1/2"	15"	1 1/8"	5 3/4"	3 1/4"	1 11/16"	5 7/8"
5233867	4"	16"	1 1/4"	6 1/8"	3 3/8"	1 3/4"	6 1/4"
5234037	5"	24"	1 13/16"	9 3/16"	3 5/8"	2"	9 3/8"
5233901	6"	30"	2 1/4"	11 1/2"	3 3/4"	2 1/8"	11 3/4"

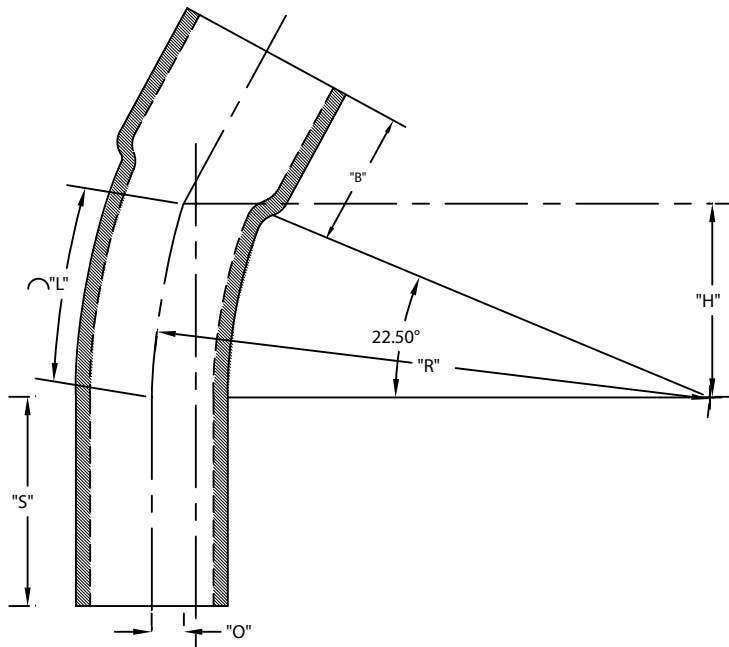

ETL LISTED
 CONFORMS TO UL651
 ETL CONTROL #3107144
 CONFORMS TO NEMA TC3
 SEE NEC ARTICLE 352 FOR USE
 MATERIAL IS RIGID PVC
 BEND TOLERANCE IS ±2°



CANTEX
 INC.
 Fort Worth, TEXAS

22-1/2° Elbows Bell End
 Schedule 40 Standard Radius Elbows

Drawn By: CD Branch

Date: 10/15/07

Ref.