

Part Number	Size	"R"	"O"	"H"	"S" Min	"L"
5121003	1/2"	4.000	1.188	2.875	1.500	3.125
5121004	3/4"	4.500	1.313	3.188	1.500	3.500
5121005	1"	5.750	1.688	4.000	1.875	4.500
5121006	1 1/4"	7.250	2.125	5.125	2.000	5.688
5121007	1 1/2"	8.250	2.375	5.875	2.000	6.500
5121008	2"	9.500	2.188	6.750	2.000	7.500
5121009	2 1/2"	10.500	2.563	7.375	3.000	8.250
5121010	3"	13.000	3.813	9.188	3.125	10.250
5121011	4"	16.000	4.688	11.438	3.375	12.625
5121012	5"	24.000	7.000	17.000	3.625	18.875
5121013	6"	30.000	8.813	21.125	3.750	23.875

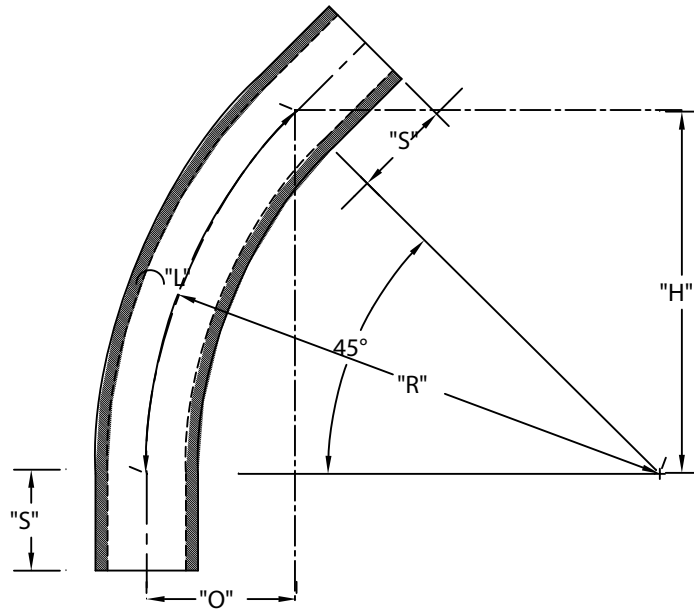

ETL LISTED  
 CONFORMS TO UL651  
 ETL CONTROL #3107144  
 CONFORMS TO NEMA TC3  
 SEE NEC ARTICLE 352 FOR USE  
 MATERIAL IS RIGID PVC  
 BEND TOLERANCE IS  $\pm 2^\circ$



**CANTEX**  
 INC.  
 Fort Worth, TEXAS

45° Elbows Plain End  
 Schedule 80 Standard Radius Elbows

Drawn By: CD Branch

Date: 10/15/07

Ref.