

Liquidtight Enviro-Flex® Straight Connectors

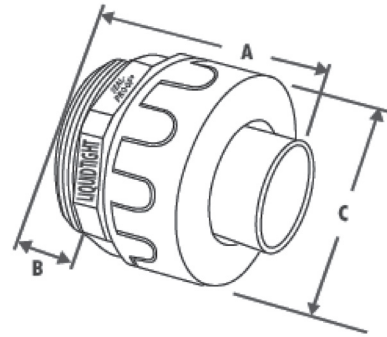

Enviro-Flex® Straight Liquidtight Connector is used to connect Enviro-Flex nonmetallic liquidtight flexible tubing to a box opening or threaded female fitting.

- Use with Enviro-Flex Liquid Tight Conduit
- For use in wet or damp locations
- Durable non-conductive PVC will not rust or corrode
- Polypropylene sealing ring
- UL listed



Part No.	Size	Carton Qty.	A	B	C
6441000	3/8	100	2.000	.540	1.400
6441001	1/2	100	2.000	.540	1.400
6441002	3/4	50	2.200	.635	1.700
6441003	1	25	2.280	.740	2.000
6441004	1-1/4	25	2.440	.760	2.400
6441005	1-1/2	10	2.700	.800	2.670
6441006	2	10	2.990	.850	3.280

Dimensions are nominal

The Enviro-Flex® Conduit and Fittings Line

The Enviro-Flex® Liquidtight Nonmetallic Flexible Conduit & Fittings Line

Enviro-Flex® Straight Liquidtight Connectors are part of the the CANTEX Enviro-Flex line. Our Enviro-Flex products provide complete environmental protection for exposed cable installations. Enviro-Flex products are ideal for use with control and motor applications, machinery tools, moving machinery, console wire, transformer connections, outdoor lighting, air conditioning systems, heating systems and computer power distribution. Enviro-Flex line includes flexible conduit, connector fittings and flexible elbows.

Enviro-Flex offers the following advantages compared to metal conduit:

• **INSTALLATION**

1. Enviro-Flex costs less to install.
2. It is easy to cut with no jagged edges.
3. It is less than half the weight of metal and can utilize all existing liquid tight fittings.

• **FLEXIBILITY**

1. Enviro-Flex is more flexible.
2. Its smooth inner bore makes pulling wires easier than ever.

• **SERVICE ENVIRONMENT**

1. Enviro-Flex is waterproof, acid, oil, alkaline and corrosion resistant.
2. It is non-conductive, self-extinguishing and extremely resistant to crush, abrasion and strain.
3. UL listed for constant use at maximum 60°C (140°F) and for sunlight resistance.

